

(Etiquette signalétique)
(Data label)

PHRIE / PHIE

PHRIE 095
PHRIE 125

PHIE 095
PHIE 125

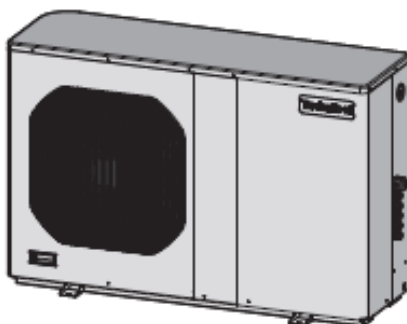

PHRIE 155
PHRIE 157
PHRIE 175
PHRIE 177
PHRIE 195
PHRIE 197
PHRIE 257
PHRIE 307

PHIE 155
PHIE 157

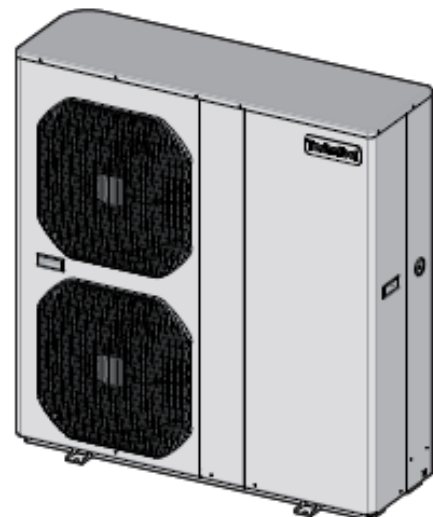

Pompe à chaleur monobloc Inverter air / eau
Moyenne température - *Fluide réfrigérant R 410 A*

Inverter monoblock air to water heat pump
Medium temperature - *R 410 A refrigerant*

GB

MARKING CE

This product marked **CE** conforms to the essential requirements of the Directives:

- Low voltage no. 2006/95/EC.
- Electromagnetic Compatibility no. 2004/108/EC.



 **NOTE:** This symbol mark and recycle system are applied only to EU countries and not applied to the countries in the other area of the world.

Your product is designed and manufactured with high quality materials and components which can be recycled and reused. This symbol means that electrical and electronic equipment, at their end-of-life, should be disposed separately from your household waste.

Please dispose of this equipment at your local community waste collection / recycling centre.

In the European Union there are separate collection systems for used electrical and electronic products.

Please help us to conserve the environment we live in!

SUMMARY

- 1 - Generalities 3
- 2 - Presentation 5
- 3 - Installation 8
- 4 - Connections 9
- 5 - Accessories 13
- 6 - Starting 15
- 7 - Maintenance instructions 21
- 8 - Electrical diagrams 23

APPLIANCES FILLED WITH R 410 A

R 410 A

- R 410 A is a high-pressure refrigerant (+ 50% in relation to R 22 and R 407 C).
- The compressors approved for operation with this fluid are filled beforehand with polyvinyl ether oil.

MAINTENANCE INSTRUCTIONS

- 1 - Never add oil to the appliance; the compressor is filled with polyvinyl ether (PVE) oil, a special oil which cannot tolerate the presence of other oils.
- 2 - The instruments used for:
 - filling,
 - pressure measurements,
 - emptying under vacuum,
 - recovering the fluid,
 must be compatible and only used for the R 410 A fluid.
 Note: the pressure taps of the refrigerating circuit are 5/16 SAE (1/2 - 20 - UNF).
- 3 - In the case of a new charge:
 - the charge **must** be undertaken in liquid phase,
 - use a balance and a dip pipe type R 410 A cylinder,
- 4 - In case of leakage, do not complete the charge: recover the remaining refrigerant for recycling and perform a total charge.
 Recovery, recycling or the destruction of the fluid must be done in compliance with the laws in force in the country concerned.
- 5 - If the refrigerant circuit is opened, you must:
 - avoid the entry of air into the circuit as much as possible,
 - replace or install a drier,
 - perform the "vacuum operation" at a minimum level of **0.3 mbar (static)**.
- 6 - Do not release R 410 A fluid into the atmosphere. This fluid is a fluorinated greenhouse gases, covered by the Kyoto Protocol with a Global Warming Potential (GWP) = 1975 - (CE Directive 842 / 2006).

1 - GENERALITIES

GB

1.1 - GENERAL SUPPLY CONDITIONS

- Generally speaking, the material is transported at the consignee's risk.
- The consignee must immediately provide the carrier with written reserves if he finds any damage caused during transport.

1.2 - RECOMMENDATIONS

- Prior to all servicing or other actions on the equipment, installation, commissioning, operation, or maintenance, the personnel in charge of these operations shall become familiar with the instructions and recommendations provided in the installation manual of the unit as well as the elements of the project's technical file.
- The personnel responsible for receiving the unit must conduct a visual inspection in order to identify all damage to which the unit may have been subjected during transport: refrigerating circuit, electrical cabinet, chassis and cabinet.
- The unit must be installed, started, maintained, serviced by qualified and authorised personnel, in compliance with the requirements of all directives, laws and regulations and in accordance with standard trade practices.
- During installation, troubleshooting and maintenance operations, the use of pipes as a step: under the stress, the pipe may rupture and the refrigerant may cause serious burns.

1.3 - VOLTAGE

- Before carrying out any operation, check that the voltage indicated on the unit corresponds to the mains voltage.
- Before initiating maintenance or servicing on the installation, check that its power supply is disconnected and locked out.

1.4 - USE OF EQUIPMENT

- This device is designed for heating buildings.



IMPORTANT

This appliance is not designed to be used by people (including children) whose physical, sensory or mental capacities are impaired, or who lack experience or knowledge, unless they are supervised or have received instructions on how to use the appliance by a person who is responsible for their safety. Children must be supervised to ensure that they do not play with the appliance or its accessories.

1.5 - OPERATING CONDITIONS

- Refer to the characteristics in the technical instructions 10 12 202, in particular to check the good selection of the apparatus.
- Reminder:
 - Water system pressure: minimum: 1.5 bar, maximum: 2.5 bar.
 - Water temperature:
 - The maximum allowable water temperature at the inlet of the heat pump off is 75°C.
 - Water volume of system: to be compulsorily checked.

			PHRIE 095 PHIE 095	PHRIE 125 PHIE 125	PHRIE 155 PHRIE 157 PHIE 155 PHIE 157	PHRIE 175 PHRIE 177	PHRIE 195 PHRIE 197	PHRIE 257	PHRIE 307
Minimum water volume (*)	litres		60	70	125	140	150	220	280
Maximum water volume at water outlet temperature (**)	25°C	litres	530	530	800	800	800	1,060	1,060
	35°C	litres	270	270	400	400	400	530	530
	45°C	litres	160	160	245	245	245	325	325
	55°C	litres	110	110	165	165	165	220	220

(*) If the water volume of the system is below the minimum, a buffer tank must be installed. For the minimum water volume, consider the volume continuously connected to the heat pump (don't consider the volumes which could be isolated by automatic valves).

(**) If the water volume of the system is above the maximum, an additional expansion vessel is required.

1.6 - OPERATING LIMITS

- Devices reduce or prohibit operation of the appliance outside these limits.

GB

- HEATING MODE OPERATING LIMITS:

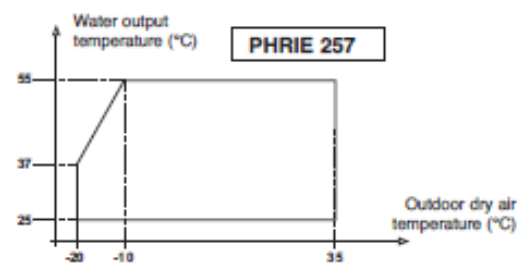
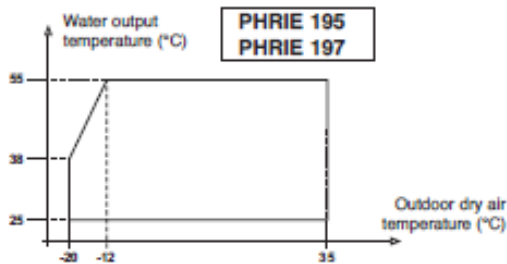
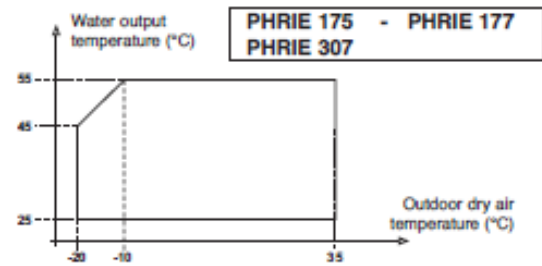
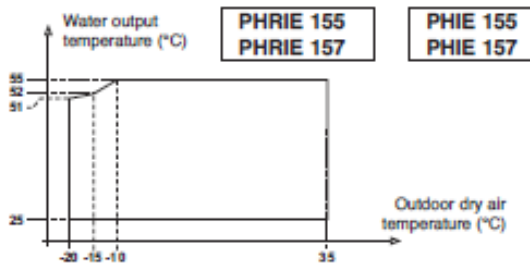
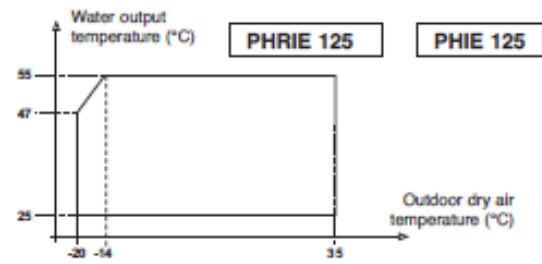
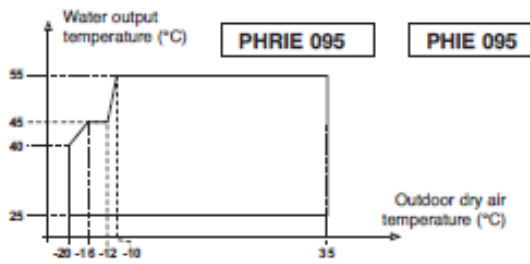

- COOLING MODE OPERATING LIMITS:

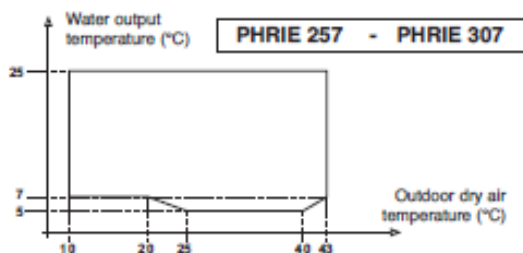
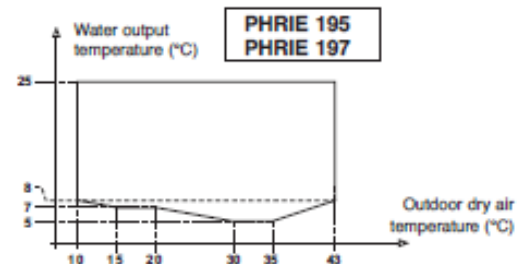
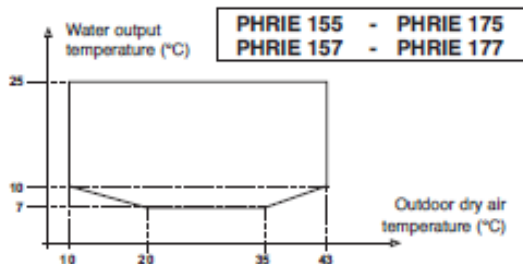
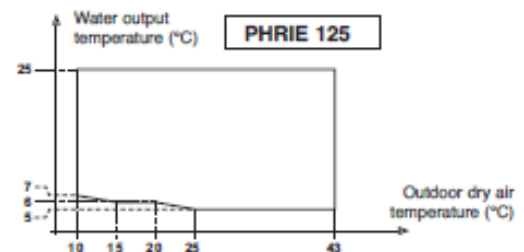
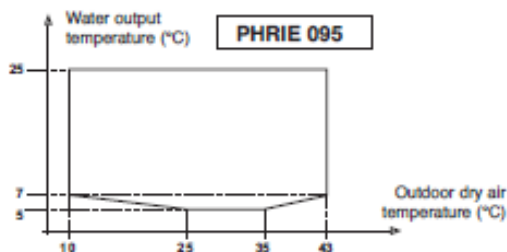

2 - PRESENTATION

2.1 - DESCRIPTION

GB

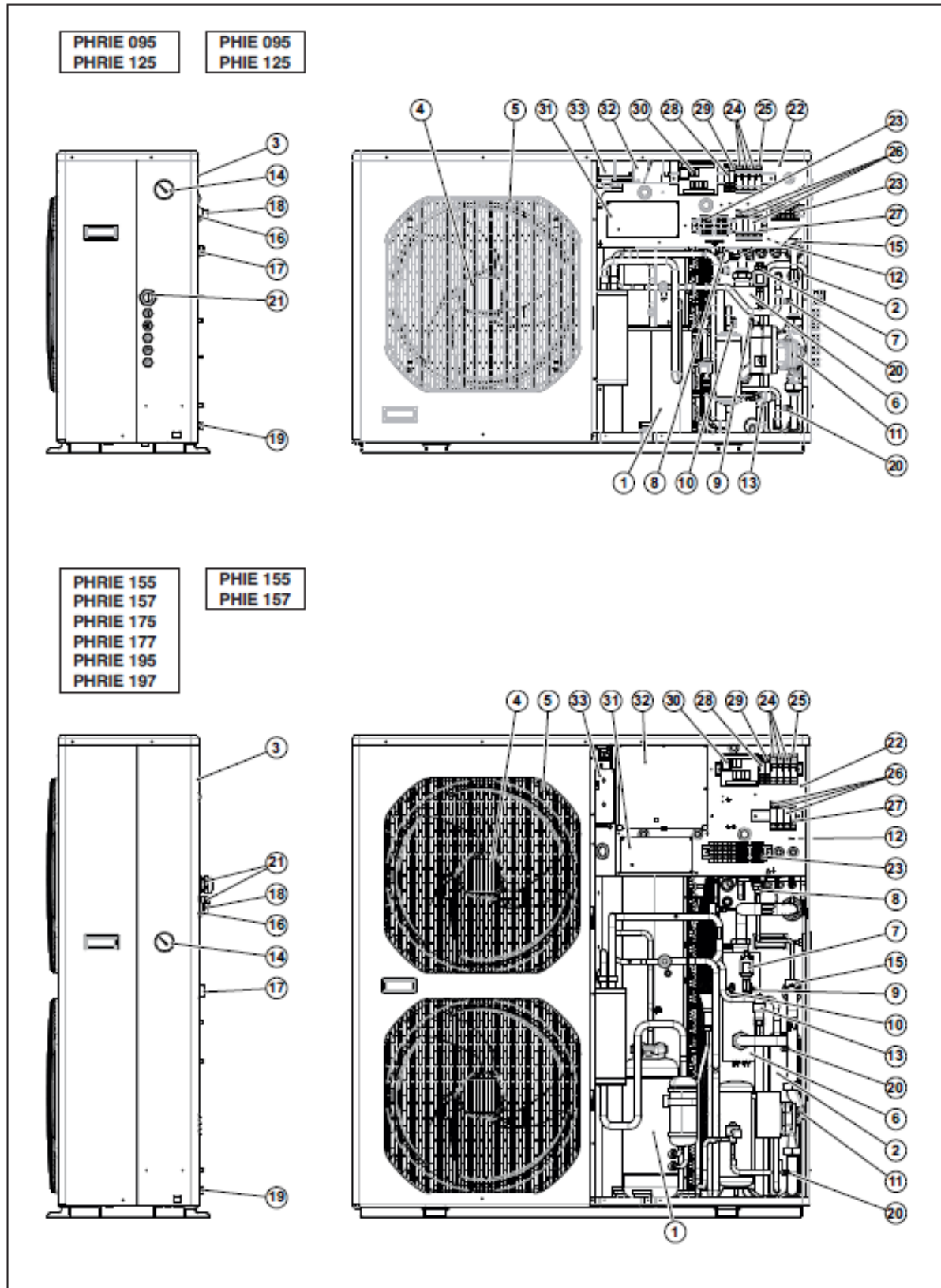

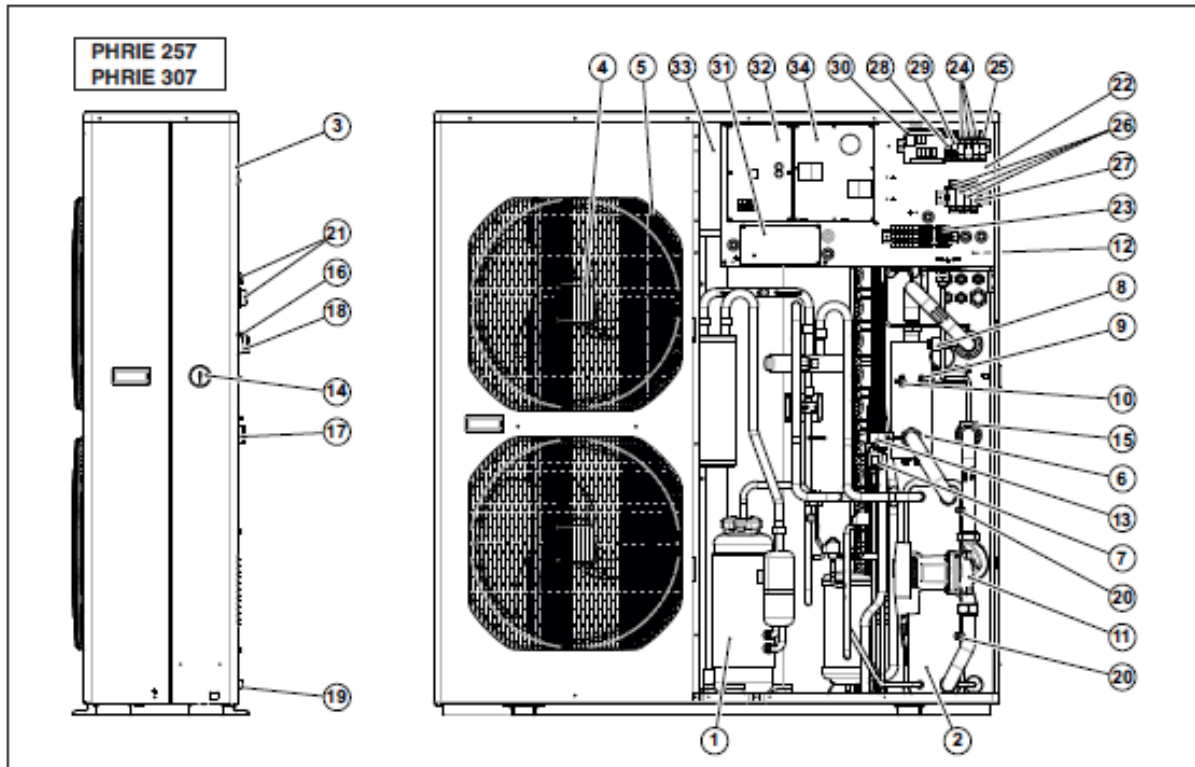

- | | |
|---|---|
| <p>1 - Sound-proofed hermetic compressor.</p> <p>2 - Brazed plate heat exchanger.</p> <p>3 - "Plate-Fin" air heat exchanger.</p> <p>4 - Fan motor.</p> <p>5 - Fan protection grille.</p> <p>6 - Electric heater:</p> <p>PHRIE 095 / 125, PHIE 095 / 125:</p> <ul style="list-style-type: none"> • 3 kW: 1st stage = 1.5 kW; 2nd stage = 1.5 kW. • 4.5 kW: 1st stage = 3 kW; 2nd stage = 1.5 kW. <p>PHRIE 155 / 157 / 175 / 177 / 195 / 197, PHIE 155 / 157:</p> <ul style="list-style-type: none"> • 4 kW: 1st stage = 2 kW; 2nd stage = 2 kW. • 6 kW: 1st stage = 4 kW; 2nd stage = 2 kW. <p>PHRIE 257 / 307:</p> <ul style="list-style-type: none"> • 6 kW: 1st stage = 3 kW; 2nd stage = 3 kW. • 9 kW: 1st stage = 6 kW; 2nd stage = 3 kW. <p>7 - Frigorific pressure sensor.</p> <p>8 - Water pressure switch.</p> <p>9 - Automatic reset safety thermostat (Heater).</p> <p>10 - Manual reset safety thermostat (Heater).</p> <p>11 - Circulating pump.</p> <p>12 - Expansion vessel.</p> <p>13 - Safety valve.</p> <p>14 - Hydraulic system pressure gauge.</p> <p>15 - Water flow switch.</p> | <p>16 - Hydraulic circuit manual air purge valve.</p> <p>17 - Water inlet connection.</p> <p>18 - Water outlet connection.</p> <p>19 - Hydraulic circuit fill / drain connection.</p> <p>20 - Water system pressure tap for flow control.</p> <p>21 - Electrical cable passage.</p> <p>22 - Electrical box.</p> <p>23 - Terminal block.</p> <p>24 - Heating element circuit breakers.</p> <p>25 - Control circuit circuit-breaker.</p> <p>26 - Heating element contactors.</p> <p>27 - Circulating pump contactors.</p> <p>28 - Fault relays.</p> <p>29 - Water flow rate relay.</p> <p>30 - System control board.</p> <p>31 - CWC2 control board.</p> <p>32 - Refrigerating circuit control board.</p> <p>33 - HIC board.</p> <p>34 - Power filter board (PHRIE 257 and 307 only).</p> <p>Materials:</p> <ul style="list-style-type: none"> - Copper piping. - Copper / aluminium air heat exchanger. - Stainless steel water heat exchanger. - Painted sheet metal cabinet. - Plastic grille. |
|---|---|

2.2 - ACCESSORIES INCLUDED WITH THE APPARATUS

• Hydraulic filter:

3/4" FF for PHRIE 095 / 125, PHIE 095 / 125.

1" FF for PHRIE 155 / 157 / 175 / 177 / 195 / 197, PHIE 155 / 157.

1" 1/4 FF for PHRIE 257 / 307.

• Anti-vibration mountings.



2.3 - DIMENSIONS AND WEIGHT

GB

Model	Weight (kg)	Model	Weight (kg)	Model	Weight (kg)
PHRIE 095	90	PHRIE 157	142	PHRIE 197	150
PHIE 095	90	PHIE 157	142	PHRIE 257	177
PHRIE 125	93	PHRIE 175	145	PHRIE 307	180
PHIE 125	93	PHRIE 177	144		
PHRIE 155	143	PHRIE 195	151		
PHIE 155	143				

		PHRIE 095 PHIE 095	PHRIE 125 PHIE 125	PHRIE 155 PHIE 155 PHRIE 157 PHIE 157	PHRIE 175 PHRIE 177	PHRIE 195 PHRIE 197	PHRIE 257 PHRIE 307
1	Water inlet connection (male)	3/4"	3/4"	1"	1"	1"	1" 1/4
2	Water outlet connection (male)	3/4"	3/4"	1"	1"	1"	1" 1/4
3	Water circuit fill / drain (male)	1/2"	1/2"	1/2"	1/2"	1/2"	1/2"
4	Holes for electric cables						

PHRIE 095
PHRIE 125

PHIE 095
PHIE 125

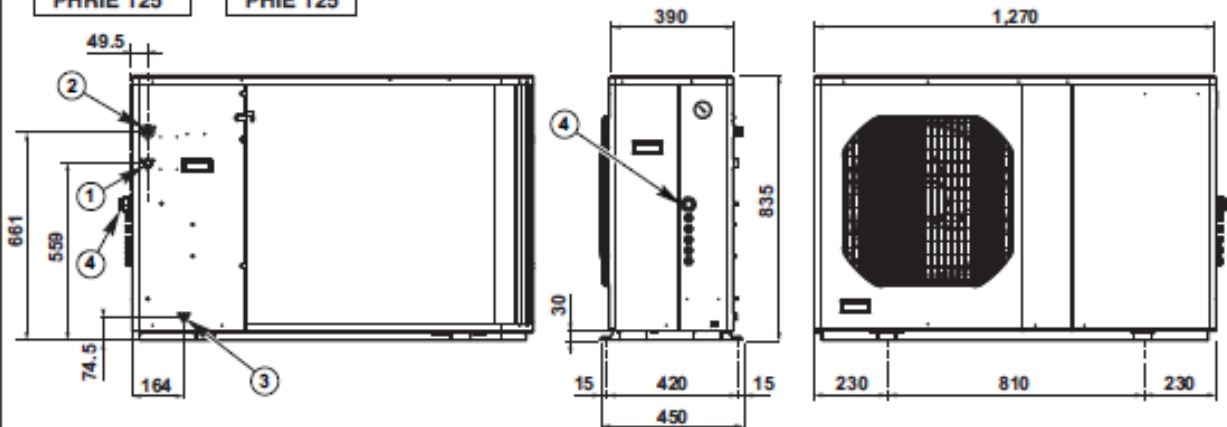

PHRIE 155
PHRIE 157
PHRIE 175
PHRIE 177
PHRIE 195
PHRIE 197

PHIE 155
PHIE 157

Model	A (mm)	B (mm)
PHRIE 155 / 157 / 175 / 177 PHIE 155 / 157	1,270	810
PHRIE 195 / 197	1,440	980

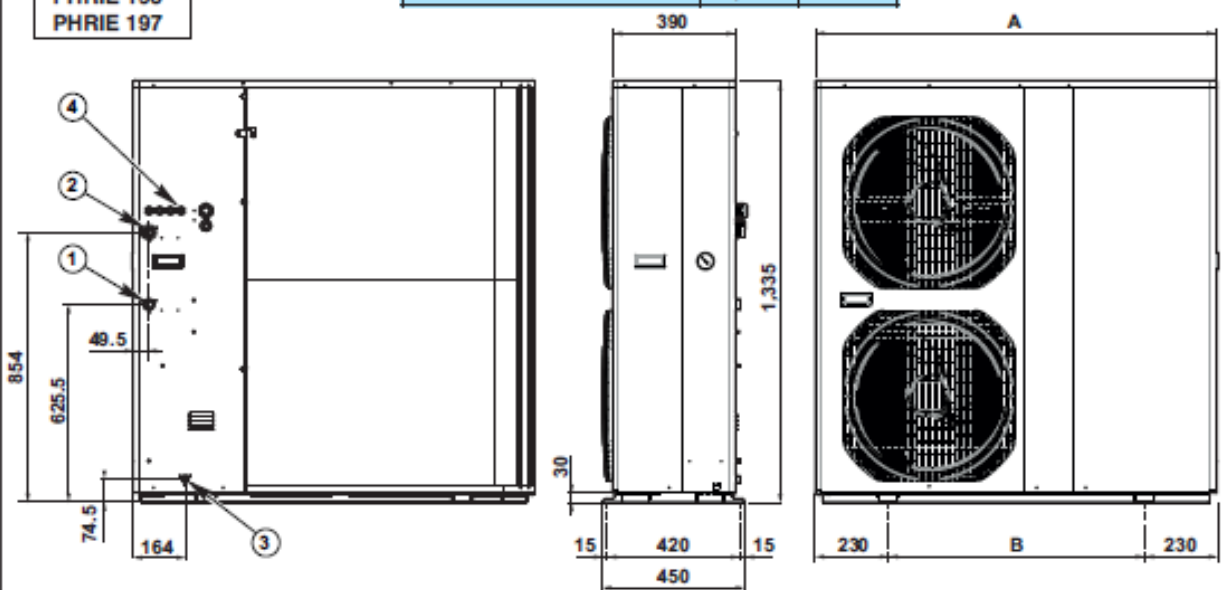

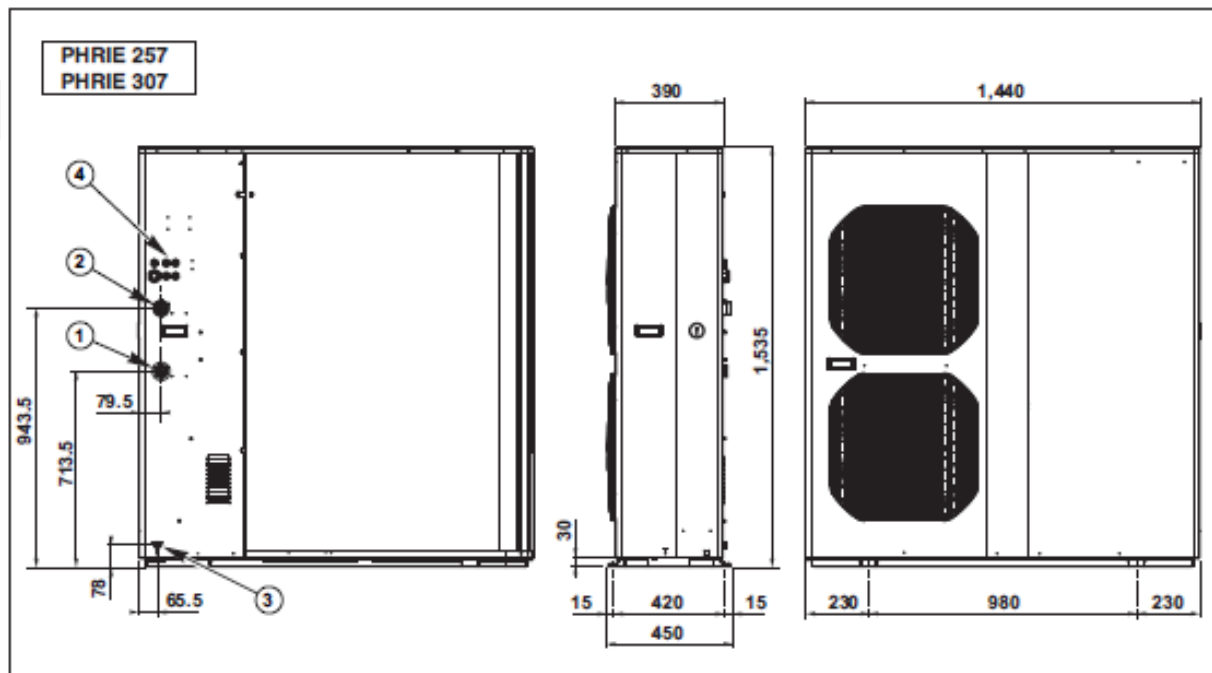

3 - INSTALLATION

3.1 - UNIT INSTALLATION

- Protection index of the unit: IP 24.
- Select the location for the unit on the basis of the following criteria:
 - The unit must be installed outside, on a slab or anti-vibration pads isolating the unit from the building,
 - The unit must not be installed near the following:
 - Sources of heat.
 - Combustible materials.
 - Return / air intake of an adjacent building.
 - Avoid:
 - Exposure to salty air or sulphuric gas.
 - The proximity of the extractor fan.
 - Projections of mud (next to a roadway or path, for example).
 - Areas where there is strong wind blowing against the unit's air exhaust.
- Due to disturbance which may be caused by the noise, the blown air must not be directed towards surrounding windows.
- It is necessary to make sure that the free space around the unit is provided (see the minimum dimensions on the drawing opposite).
- Installation must be simple and make maintenance work easy.
- The unit must be fixed on a hard base and must be protected from risks of flooding.
- The unit must be installed horizontally and level.
- The unit **must be raised** approximately 100 mm above the ground to facilitate the drainage of condensates from the drain pan and to prevent it from being encased in ice. The drain pan is equipped with several $\varnothing 32$ mm drainage holes under the air exchanger.
- Use the anti-vibration mountings supplied, making sure that they are not compressed too much when the fastening screws are tightened.
- Vibrations and noise must not be transmitted to a nearby building.

Minimum space above the device: 0.70 m.

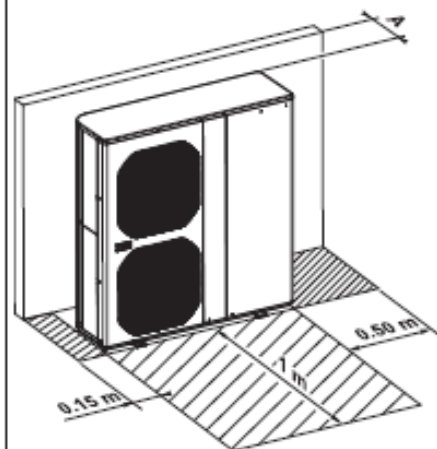

Model	A (m)*
PHRIE 095 / 125 PHIE 095 / 125	0.20
PHRIE 155 / 157 PHIE 155 / 157 PHRIE 175 / 177 PHRIE 195 / 197	0.25
PHRIE 257 / 307	0.30

* This dimension does not account for the installation of the hydraulic filter with two shut-off valves positioned behind the unit.

4 - CONNECTIONS

4.1 - DISASSEMBLY

- To remove side panel **A**:
 - Remove the retaining screws **B**.
 - Lower the panel (**1**) using the handle **C**.
 - Pull the lower part of the panel toward you (**2**).

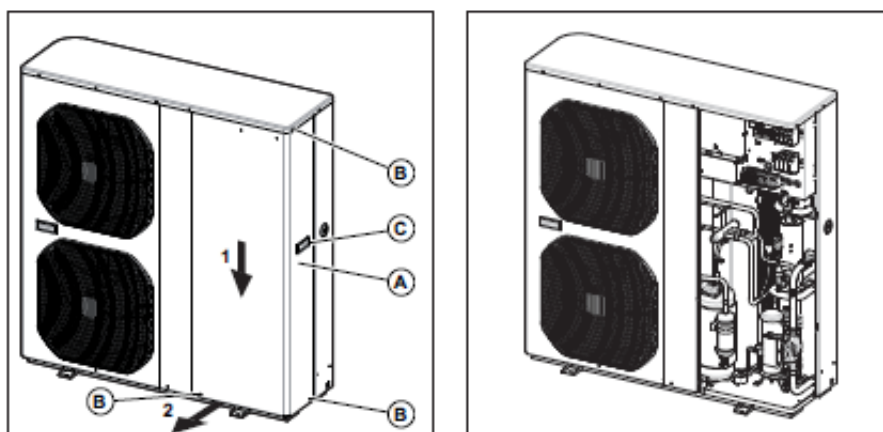

4.2 - HYDRAULIC CONNECTION

- Connect the water pipes to the corresponding connections (see pages 7 and 8).
- Install the hydraulic filter (supplied) on the water intake. Connect it using 2 isolation valves (not supplied) for cleaning purposes.
- Install a shut-off valve (not supplied) if a fill / drainage connection is used.

NOTE: "Water connection hose" accessories may be used (refer to the accessories paragraph).

4.3 - ELECTRICAL CONNECTION

4.3.1 - GENERAL:

- The acceptable voltage variation is: $\pm 10\%$ during operation.
- The electrical connection conduits must be fixed.
- Use the cable clamps at the rear of the unit and route the wires under the electric panel, at the level of the terminal blocks.
- Class 1 unit.
- The electrical installation must comply with the standards and regulations applicable where the unit is being installed (in particular NF C 15-100 = IEC 364).

4.3.2 - POWER SUPPLY

- The power supply must come from an isolation and electric protection device (not supplied) in accordance with existing regulations.
- A **two-pole circuit breaker** (not supplied) must be installed to protect single-phase equipment or a **three-pole circuit breaker** (not supplied) for three-phase equipment. See the intensity ratings table.

Note 1:

The unit is designed to be connected to a power supply having a TT neutral regime (neutral to ground) or TN.S regime (to neutral) as per NF C 15-100.

Note 2:

The sizing of the power supply cables is to be ensured by the installer in accordance with the installation conditions and as per current standards.

Cable sizes, indicated below, are given for information purposes.

They are calculated in accordance with NFC 15-100 (= IEC 364) with the following hypotheses:

- Maximum current, see table below.
- Multi-pole copper cable with PR insulation.
- Installation in conduit (installation method No. 3 A / 4 A / 5 A). No other power cable.
- Ambient temperature 35°C.

Note 3: Electromagnetic compatibility - Harmonic currents:

- Models **PHRIE 095** and **PHIE 095** comply with the requirements of standard EN61000-3-12 defining the limits for harmonic current emissions.
- Models **PHRIE 125**, **PHIE 125**, **PHRIE 155**, **PHIE 155**, **PHRIE 157**, **PHIE 157**, **PHRIE 175**, **PHRIE 177**, **PHRIE 195** and **PHRIE 197** comply with the requirements of standard EN61000-3-12 defining the limits for harmonic current emissions. For these models, the minimum short-circuit ratio "R_{sce}" value to be respected is **120**.

This value must be checked according to the characteristics of the network to which the installation is connected.

$$\text{Single-phase} \quad R_{sce} = \frac{Sc}{3 \times Seq}$$

$$\text{Three-phases} \quad R_{sce} = \frac{Sc}{Seq}$$

- Such that: **Sc** = Three-phases short-circuit power of the network.

$$Sc = \frac{U_{nominal}^3}{Z}$$

where: **U_{nominal}** = nominal voltage between phases,

Z = impedance of the network at the main's frequency.

- Such that: **Seq** = Assigned apparent power of the unit,

$$\text{single-phase} \quad Seq = U_p \times I_{abs} \quad (U_p = \text{single-phase voltage}),$$

$$\text{three-phase} \quad Seq = \sqrt{3} \times U_j \times I_{abs} \quad (U_j = \text{voltage between phases}).$$

- Models **PHRIE 257** and **PHRIE 307** comply with the requirements of standard EN61000-3-12 defining the limits for harmonic current emissions. For these models, the minimum short-circuit ratio "R_{sce}" value to be respected is **66**.
- If a heat pump without electric support is used, take a short-circuit "R_{sce}" value of **350**.

POWER SUPPLY CABLE

- **Section:** see table currents and cross-section.
- The sections are given as an indication only. They have to be verified and adapted, if necessary, according to the installation conditions and the standards in force.
- Connect to the electrical panel's power terminal block as per the wiring diagram.

CURRENTS AND CROSS-SECTIONS:

- Single-phase models:

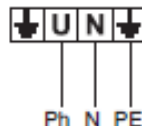

SINGLE-PHASE MODELS	PHRIE 095 PHIE 095 230/1/50	PHRIE 125 PHIE 125 230/1/50	PHRIE 155 PHIE 155 230/1/50	PHRIE 175 230/1/50	PHRIE 195 230/1/50	
Heat pump only (for boiler back-up application) (**)						
Nominal current (*)	A	5.5	10.3	11	15.1	18.9
Maximum current	A	11.7	17.3	20	22	26.6
Compressor start-up current	A	3	3	3	3	3
Protection rating	A	16	20	25	25	32
Cross-section of power cable		3 G 2.5 mm ²	3 G 4 mm ²	3 G 4 mm ²	3 G 4 mm ²	3 G 6 mm ²

(*) At water temperature 30/35°C and air temperature 7/6°C (dry / humid).

(**) **Caution:**



In the event of a possible return to a standard configuration: heat pump + electric heater, the electrical connection conduit should be changed.

Note 4: Electromagnetic compatibility - Fluctuations of voltage and flicker.

PHRIE / PHIE comply with the requirements of standard EN61000-3-11.

For models **PHRIE 257** and **PHRIE 307** the maximum impedance of the network Z_{max} is 0.134 Ω (value determined with maximum electric support power).

SINGLE-PHASE MODELS		PHRIE 095 PHIE 095 230/1/50	PHRIE 125 PHIE 125 230/1/50	PHRIE 155 PHIE 155 230/1/50	PHRIE 175 230/1/50	PHRIE 195 230/1/50
Heat pump + support heater						
Maximum total current with 3 kW support heater	A	24.7	30.3	–	–	–
Maximum total current with 4.5 kW support heater	A	31.3	36.9	–	–	–
Maximum total current with 4 kW support heater	A	–	–	37.4	39.4	44
Maximum total current with 6 kW support heater	A	–	–	46.1	48.1	52.7
Protection rating	A	40	40	50	50	63
Cross-section of power cable		3 G 6 mm ²	3 G 6 mm ²	3 G 10 mm ²	3 G 10 mm ²	3 G 16 mm ²

- Three-phase models:

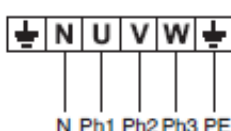

Adhere to the order of the phases.

THREE-PHASE MODELS		PHRIE 157 PHIE 157 400/3N/50	PHRIE 177 400/3N/50	PHRIE 197 400/3N/50	PHRIE 257 400/3N/50	PHRIE 307 400/3N/50
Heat pump only (for boiler back-up application) (**)						
Nominal current (*)	A	4	4.8	5.5	8.6	9.4
Maximum current	A	11.3	12.2	11	12.7	16.5
Compressor start-up current	A	3	3	3	3	3
Protection rating	A	16	16	16	16	20
Cross-section of power cable		5 G 2.5 mm ²	5 G 2.5 mm ²	5 G 2.5 mm ²	5 G 2.5 mm ²	5 G 4 mm ²

(*) At water temperature 30/35°C and air temperature 7/6°C (dry / humid).

(**) **Caution:**

In the event of a possible return to a standard configuration: heat pump + electric heater, the electrical connection conduit should be changed.

Heat pump + support heater						
Maximum total current with 4 kW support heater	A	17.1	18	16.8	–	–
Maximum total current with 6 kW support heater	A	20	20.9	19.7	21.4	25.2
Maximum total current with 9 kW support heater	A	–	–	–	25.7	29.5
Protection rating	A	25	25	25	32	32
Cross-section of power cable		5 G 4 mm ²	5 G 4 mm ²	5 G 4 mm ²	5 G 6 mm ²	5 G 6 mm ²

ELECTRIC SUPPORT HEATER POWER

• The unit is supplied for support power of:

- 3 kW (1.5 + 1.5) for PHRIE 095, PHIE 095, PHRIE 125 and PHIE 125.
- 4 kW (2 + 2) for PHRIE 155, PHIE 155, PHRIE 157, PHIE 157, PHRIE 175, PHRIE 177, PHRIE 195 and PHRIE 197.
- 6 kW (3 + 3) for PHRIE 257 and PHRIE 307.

By creating a bridge (supplied) across the terminals (22) and (23), the support power goes to:

- 4.5 kW (3 + 1.5) for PHRIE 095, PHIE 095, PHRIE 125 and PHIE 125.
- 6 kW (4 + 2) for PHRIE 155, PHIE 155, PHRIE 157, PHIE 157, PHRIE 175, PHRIE 177, PHRIE 195 and PHRIE 197.
- 9 kW (6 + 3) for PHRIE 257 and PHRIE 307.

4.3.3 - CONTROL CONNECTIONS

According to the system control kit associated to the heat pump.

2 possibilities:

• **System control kit K60D070Z** for standard applications using heat pump with **electric support heater**:

- 1 Floor Zone,
- 2 Floor Zones,
- 1 Terminal Units Zone,
- 1 Radiators Zone (with or without Domestic Hot Water),
- 2 Mixed Zones - Floor + Terminal Units,
- 2 Mixed Zones - Floor + Radiators.

System control kit includes:

- The control unit.
- The outdoor temperature sensor.
- System control manuals.

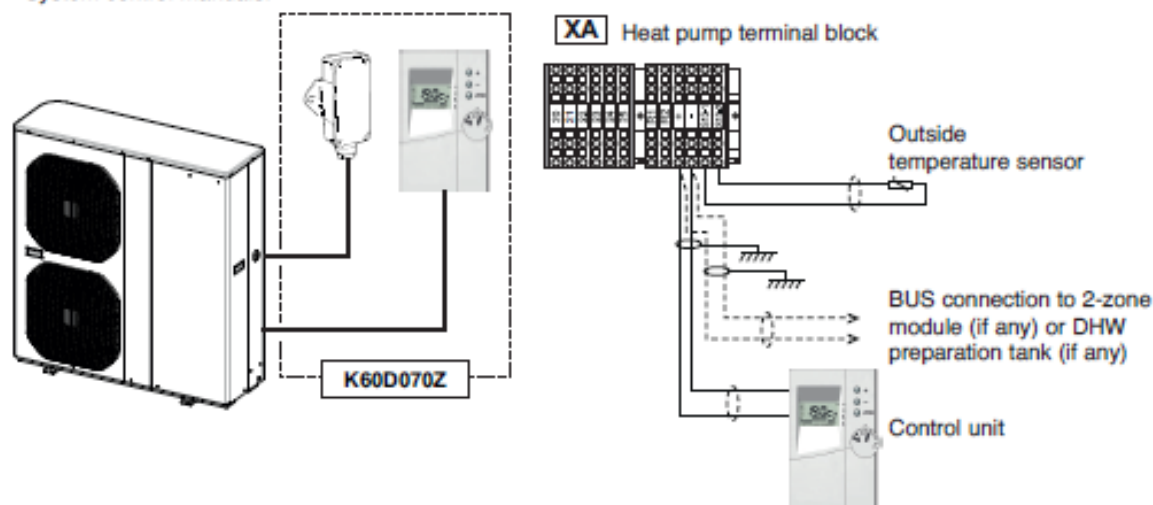

The system control electronic board and the electric support heater are built into the heat pump. Refer to the installation instructions of the control kit for the connection details.

• **System control kit K60D071Z** for heat pump in boiler back-up applications:

- 1 Floor Zone,
- 1 Radiators Zone.

System control kit includes:

- The system control unit.
- The outdoor temperature sensor.
- The installation water temperature sensor.
- The control box to be installed in a technical building.
- System control manuals.

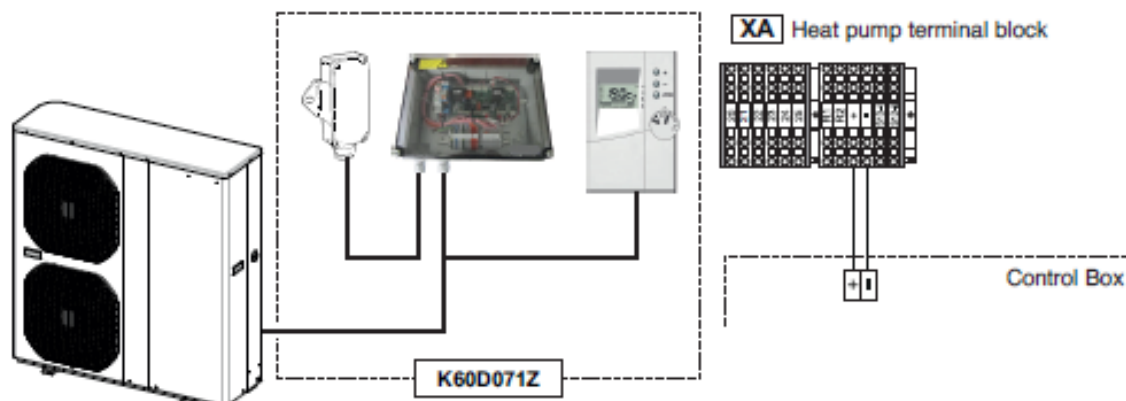

CAUTION

In this case, connection modifications are to be made in the heat pump. Refer to the installation instructions of the control kit for the connection details.

4.3.4 - MAINTENANCE KEYPAD / DISPLAY UNIT CONNECTION

- A specific keypad / display unit can be connected for maintenance and troubleshooting operations. See maintenance manual.

Caution:

This keypad / display unit must not be used for the installation's normal operation.

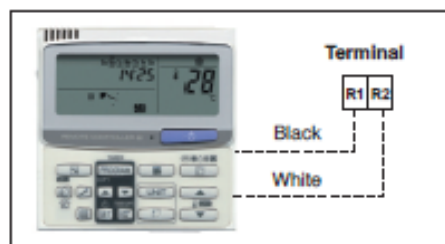

4.3.5 - ROUTING OF CABLES

- To prevent problems resulting from electromagnetic interference, control cables must not be routed near 230 VAC cables. **Particular attention should be paid to the 230 VAC pilot wire.**

- Electrical connection conduits must be fixed.

ROUTING OF HEAT PUMP CABLES

- Route the cables through the cable glands located at the back of the unit (or on the right hand side for models with only one fan).
- Use the cable clamps mounted on the lower edge of the electrical panel to secure the cables.

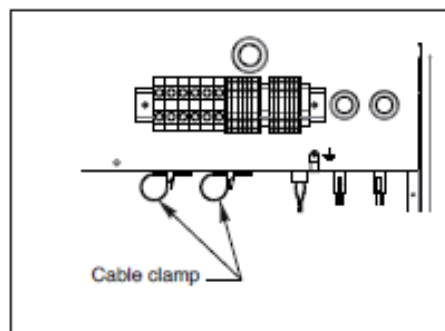

- Ground the shielding of the communication line (BUS) cable with the metal clamp secured to the box panel.

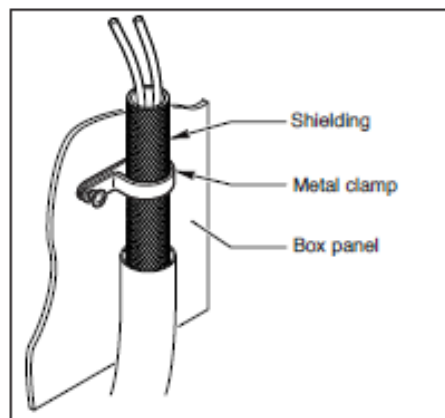

5 - ACCESSORIES

5.1 - WATER CONNECTION HOSES

Length 1 m, insulated:

- Code 70600054: Ø 3/4" female connector for PHRIE 095, PHIE 095, PHRIE 125 and PHIE 125.
- Code 70600055: Ø 1" female connector for PHRIE 155, PHIE 155, PHRIE 157, PHIE 157, PHRIE 175, PHRIE 177, PHRIE 195 and PHRIE 197.
- Code 70600027: Ø 1 1/4" female connector for PHRIE 257 and PHRIE 307.

5.2 - BASE DE-ICE ELECTRIC HEATER KIT

- Code 70200056.
- This accessory is recommended for units installed in where defrosting is frequent, with a very low ambient temperature.
- Remove the fan's protective grille (4 screws A).

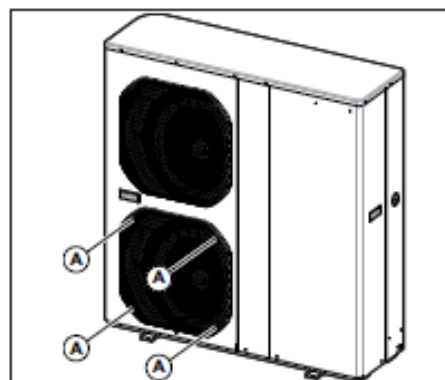

- Remove the fan blade (nut **B**).

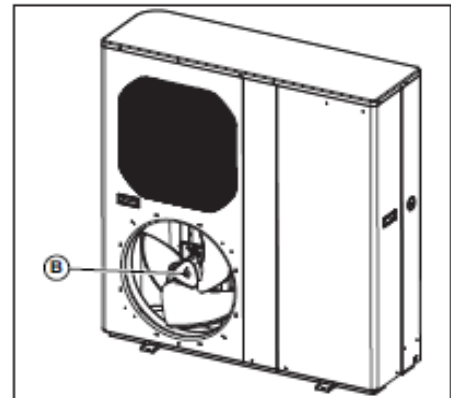

- Place the heating element in the bottom of the drain pan, along the exchanger with fins.

Caution:

The fins of the exchanger are sharp. Be careful not to cut yourself when fitting the heating element.

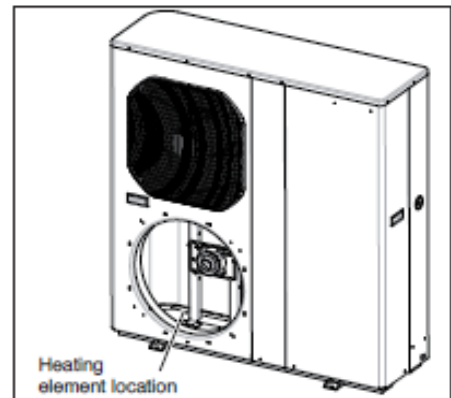

- Position the isolated end on the left side and along the exchanger to the back of the separating panel. Form a loop and return along the separating panel.
- Pass the heating element under the plastic clips fixed in the drain pan.
- Pass the end of the heating element through the grommet in the separating panel.
- Make sure that the fan blade cannot come into contact with the heating element.
- If there is no hole in the separating panel, pass the cable through the opening of the leg of the compressor. Protect the edge of the plate correctly so as not to damage the cable.

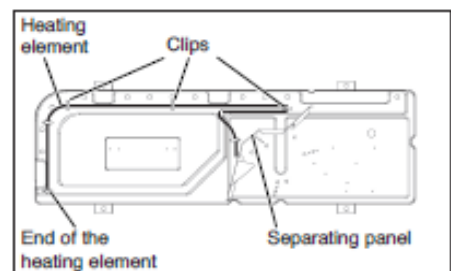

- Connect the cable to the red connector marked "DH" of the CWC2 (A2) control board.

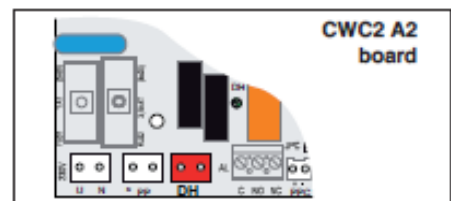

Note:

The wire heats up over a length of 1.5 m.

Be sure not to place the heating portion in contact with the wires.

Make sure that the fan blade cannot come into contact with the heating element.

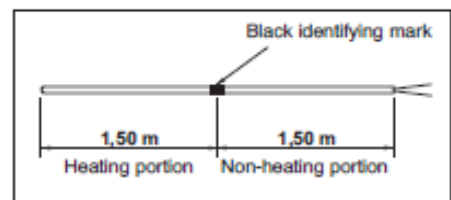

6 - STARTING

IMPORTANT NOTE

Before carrying out any work on the installation, make sure that it is switched off and that access to it is prevented.
Any work must be carried out by personnel qualified and authorised to work on this type of machine.

GB

6.1 - PRELIMINARY CHECKS

6.1.1 - HYDRAULIC CIRCUIT

- Hydraulic couplings correctly tightened.
- Hydraulic circuit operating correct:
 - Purge of circuits.
 - Position of valves.
 - Hydraulic pressure (1.5 to 2.5 bar).
- Integrity of the hydraulic circuit.
- Water quality:
 - In order for the heat pump to operate under good conditions and provide optimum performance, it is essential to ensure that the system's water circuit is clean. If the water circuit becomes clogged, this will significantly affect the machine's performance. The circuit must therefore be cleaned with suitable products in compliance with current standards as soon as it is installed, both for new and renovation work.
We recommend the use of products which are compatible with all metals and synthetic materials and approved by official bodies.
The water must adhere to the following characteristics:
 - pH: 7 to 9.
 - TH: 10 to 20°F.
 - Dry material in suspension: < 2 g/l.
 - Granulometry: < 0.4 mm.
 - Chloride: 50 mg/l maximum.
 - Conductivity: 150 to 350 $\mu\text{S}/\text{cm}^2$.
 - Fibre: no fibres.

Any disorder which may occur on our machines due to the poor quality of the fluid in the installation will not be covered by the warranty.

IMPORTANT:

If anti-freeze is added, use monopropylene glycol. A rate of 15 to 20% is required to avoid any risk of corrosion.

6.1.2 - ELECTRICAL SYSTEM

- The power cables are well fixed to their connection terminals. Terminals that are poorly tightened may cause overheating and malfunctions.
- The electric cables are well insulated from any sections of sheet metal or metal parts which could damage them.
- The probe, control and power cables are properly separated.
- The machine is earthed.
- Order of phases for three-phase models (reversal of the phases trips the safety state of the device).

6.1.3 - MISCELLANEOUS

- Overall good condition of the apparatus.
- No tools or other foreign objects inside the apparatus.

6.2 - CONFIGURATION AND PARAMETERISATION

6.2.1 - REFRIGERATING CIRCUIT CONTROL BOARD (A3)

GB

NOTE:

To access the board, remove the cover from the electrical box made of plastic (accessible after removing the top cover from the unit).

• PHRIE 095 / PHIE 095 / PHRIE 125 / PHIE 125

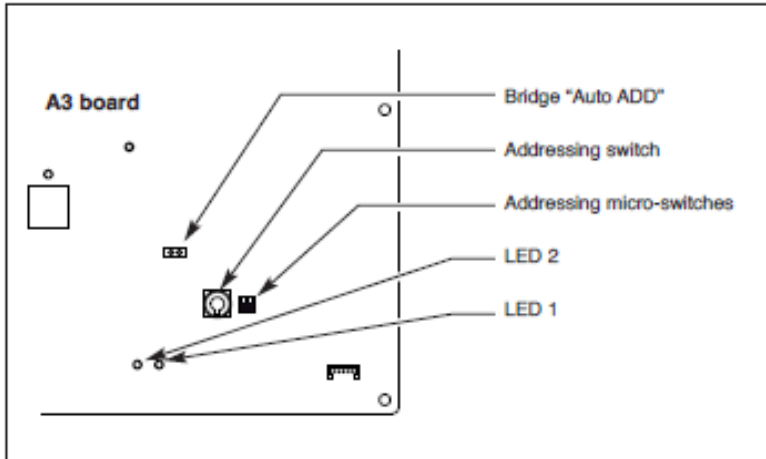

• **Addressing switch positions:**

- Factory settings: **must not be modified.**

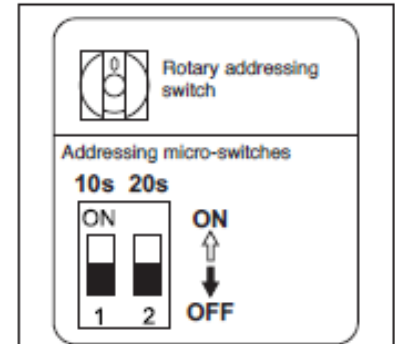

• PHRIE 155 / PHIE 155 / PHRIE 175 / PHRIE 195

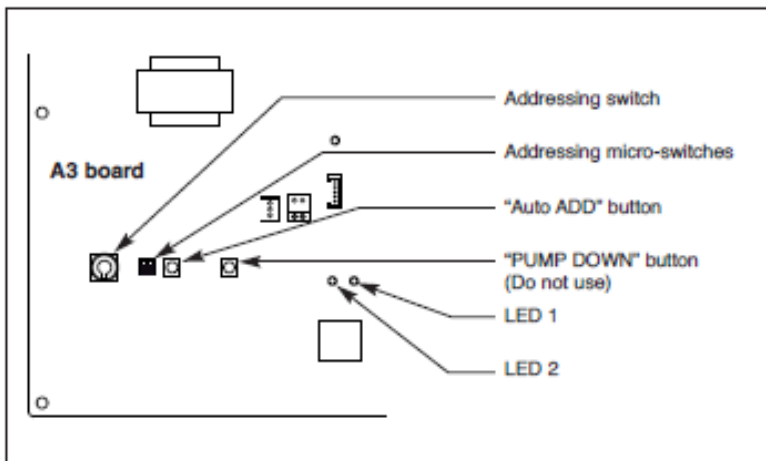

• PHRIE 157 / PHIE 157 / PHRIE 177 / PHRIE 197

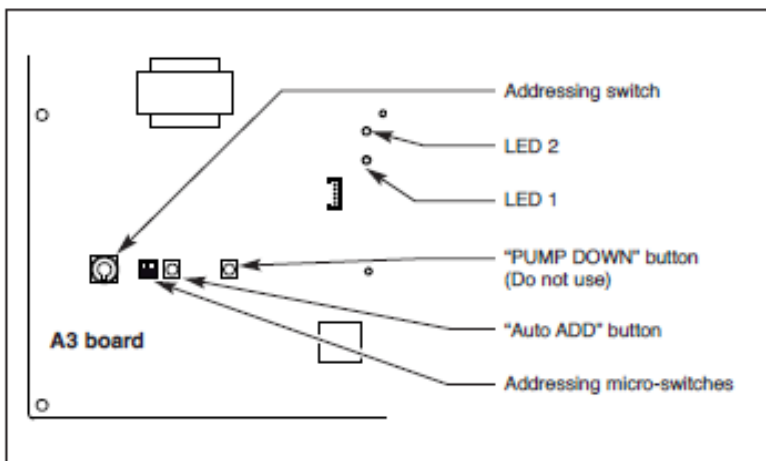

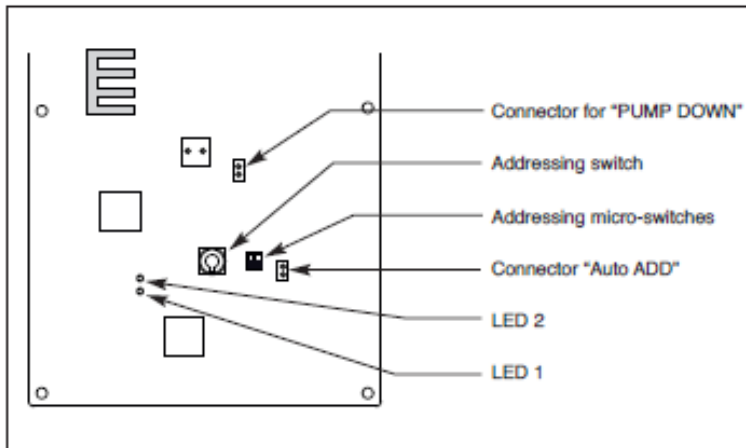

• **LED1 and LED2 indicator lights:**

- = ON steady.
- ☼ = ON blinking.
- = OFF.

Meaning	LED1	LED2	
Auto-addressing in progress (*)	☼	☼	Alternating blinking
Power ON:			
Step 1: no communication	○	○	
Step 2: communication received from the CWC2 control board	●	○	
Step 3: normal communication	●	●	
Alarm message	☼	☼	Simultaneous blinking
No charge indicator	☼	●	
Refrigerant recovery mode	☼	○	
Alarms (Refer to the details in the outdoor unit's maintenance)	☼	☼	Repeated and alternating blinking (of each indicator light)

(*) The addressing sequence of the Refrigerating Circuit Control (A3) and Control (A2) boards takes place when the power is initially turned on at the factory.
It can be repeated when a board is changed.
Refer to the maintenance manual.

6.2.2 - CWC2 CONTROL BOARD (A2)

- It ensures 3 functions:
 - Communication interface between system control and heat pump control.
 - Control and checking of the heat pump heat exchanger and water circulating pump.
 - Base de-ice electric heater control.

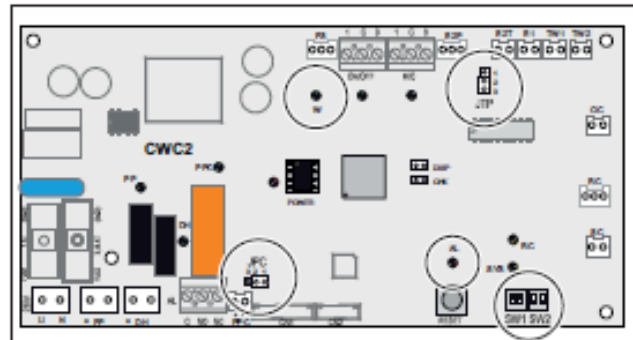

- This board is fitted out with 2 "SW1" and "SW2" micro-switches as well as "JTP" and "JPC" bridges for the configuration:

- **SW1 - 1 Micro-switch:**

In "ON" position (factory setting), the circulating pump starts automatically if the outdoor temperature is below 0°C to prevent the hydraulic circuit from freezing.



Caution: In the "OFF" position, this function is deactivated.

- **SW1 - 2 Micro-switch:**

The "ON" position (factory setting) activates the "FL" alarm (heat pump water flow rate) at the system.



Caution: For heat pump with electric support heater applications, this micro-switch must be in the "ON" position.

For heat pump in boiler back-up applications, the micro-switch must be placed in the "OFF" position.

- **SW2 - 1 micro-switch:**

The "ON" position activates the "Circulating pump speed variation" function.
The function is not available on this version.

The SW2-1 micro-switch is left in "OFF" position (factory setting).

- **SW2 - 2 micro-switch:**

To select the circulating pump speed variation control algorithm.

SW2-2 in "OFF" position (factory setting) = "PWM" control.

SW2-2 in "ON" position = "0/10V" control.

The function is not available on this version.

- **JTP bridge:**

E2P input selection.

Must be positioned on "2-3" (factory setting).

- **JPC bridge:**

Selection of type of circulating pump speed variation signal.

JPC on "1-2" = "PWM" (factory setting).

JPC on "2-3" = "0/10V".

- Alarms:

- "AL" light:

- **Flashing** = Automatic reset heat pump alarm.

- **Stays on** = Manual reset heat pump alarm.

- "W" light:

- **Off** = No water flow.

- **Stays on** = Water flow.

- **Slow flashing** = Water flow rate alarm.

(once a second)

- **Quick flashing** = Water outlet temperature too low alarm.

(twice a second)

- **Flickers** = TW2 water outlet temperature sensor fault.

6.2.3 - SYSTEM PARAMETERISATION

- Make sure that the control unit selector is "OFF".
- Check the parameterisation and adapt it accordingly based on the type of installation.
The parameters are set on the control unit (refer to the system control technical file in the control kit).

• Perform a differential pressure measurement of the pump ΔP_m . Adjust the red ΔP button in accordance with the following tables.

GB

PHRIE 095 / PHIE 095 (Wilo Stratos-Para 25/1-7)	ΔP_m measurement at high speed (m W)									Flow rate for information (m ³ /h)
	2.5	3	3.5	4	4.5	5	5.5	6	6.5	
Adjustment of button for application of 25°C	0.5	1	1	1.5	1.5	2	3	4		1.61
Adjustment of button for application of 35°C			0.5	0.5	1	1	1	1.5	2.5	0.92
Adjustment of button for application of 45°C					0.5	0.5	1	1	2	0.76
Adjustment of button for application of 55°C						0.5	0.5	1	1.5	0.67

PHRIE 125 / PHIE 125 (Wilo Stratos-Para 25/1-7)	ΔP_m measurement at high speed (m W)									Flow rate for information (m ³ /h)
	2.5	3	3.5	4	4.5	5	5.5	6	6.5	
Adjustment of button for application of 25°C	1	1	1.5	2	2.5	3	4	6		1.9
Adjustment of button for application of 35°C	0.5	0.5	1	1	1.5	2	2.5	3.5	6	1.45
Adjustment of button for application of 45°C	0.5	0.5	1	1	1.5	2	2	3.5	6	1.4
Adjustment of button for application of 55°C				0.5	0.5	0.5	1	1	2	0.82

PHRIE 155 / PHRIE 157 PHIE 155 / PHIE 157 (Wilo Stratos-Para 25/1-7)	ΔP_m measurement at high speed (m W)									Flow rate for information (m ³ /h)
	2.5	3	3.5	4	4.5	5	5.5	6	6.5	
Adjustment of button for application of 25°C	1	1.5	2	2.5	3	4	5.5			2.2
Adjustment of button for application of 35°C	1	1	1.5	1.5	2	3	3.5	5.5		1.84
Adjustment of button for application of 45°C	1	1	1	1.5	2	2.5	3.5	5		1.75
Adjustment of button for application of 55°C		0.5	0.5	0.5	1	1	1.5	2	4	1.03

PHRIE 175 / PHRIE 177 (Wilo Stratos-Para 25/1-8)	ΔP_m measurement at high speed (m W)											Flow rate for information (m ³ /h)	
	2	2.5	3	3.5	4	4.5	5	5.5	6	6.5	7		7.25
Adjustment of button for application of 25°C	0.5	0.5	1	1	1.5	2	2.5	3	3.5	5	6.5		3.2
Adjustment of button for application of 35°C					1	1	1.5	1.5	2	2.5	3.5	4.5	2.32
Adjustment of button for application of 45°C					1	1	1	1.5	2	2.5	3.5	4.5	2.28
Adjustment of button for application of 55°C									1	1.5	1.5	1.5	1.16

PHRIE 195 / PHRIE 197 (Wilo Stratos-Para 25/1-8)	ΔP_m measurement at high speed (m W)											Flow rate for information (m ³ /h)	
	2	2.5	3	3.5	4	4.5	5	5.5	6	6.5	7		7.25
Adjustment of button for application of 25°C	0.5	0.5	1	1	1.5	2	2.5	3	3.5	5	6.5		3.2
Adjustment of button for application of 35°C				1	1	1.5	1.5	2	2.5	3	4.5	5.5	2.59
Adjustment of button for application of 45°C				1	1	1	1.5	2	2.5	3	4	5	2.52
Adjustment of button for application of 55°C									1	1.5	1.5	1.5	1.3

PHRIE 257 (Wilo Stratos-Para 25/1-8)	ΔP_m measurement at high speed (m W)											Flow rate for information (m ³ /h)	
	2	2.5	3	3.5	4	4.5	5	5.5	6	6.5	7		7.25
Adjustment of button for application of 25°C	0.5	1	1.5	1.5	2	3	3.5	4.5	6				4.2
Adjustment of button for application of 35°C	0.5	0.5	1	1	1.5	2	2.5	3.5	4.5	5.5			3.51
Adjustment of button for application of 45°C	0.5	0.5	1	1	1.5	2	2.5	3	4	5	7		3.35
Adjustment of button for application of 55°C							1	1.5	1.5	2	2.5	3.5	2

PHRIE 307 (Wilo Stratos-Para 25/1-12)	ΔPm measurement at high speed (m W)								Flow rate for information (m ³ /h)
	4	4.5	5	5.5	6	6.5	7	7.5	
Adjustment of button for application of 25°C	1.5	1.5	2	2	2.5	3	3,5	4,5	5.5
Adjustment of button for application of 35°C			1.5	1.5	1.5	2	2	2	4.09
Adjustment of button for application of 45°C					1.5	2	2	2	3.75
Adjustment of button for application of 55°C									2.2

PHRIE 307 (Wilo Stratos-Para 25/1-12)	ΔPm measurement at high speed (m W)									Flow rate for information (m ³ /h)
	8	8.5	9	9.5	10	10.5	11	11.5	12	
Adjustment of button for application of 25°C	5	6	7	8	9,5					6.1
Adjustment of button for application of 35°C	2.5	3	3.5	4	4.5	5.5	6.5	8	9.5	4.09
Adjustment of button for application of 45°C	2	2.5	2.5	3	3.5	4.5	5.5	6.5	7.5	3.75
Adjustment of button for application of 55°C						2.5	2.5	2.5	2.5	2.2

6.3.5 - SHUTDOWN FORCED CIRCULATING PUMP OPERATION

- Press during 5 seconds the "RESET" button of the CWC2 control board.
The circulating pump stops.
The circulating pump indicator light "PP" and the "W" water flow rate light go out.

6.4 - OPERATION

- Turn on the installation power five hours before start-up to preheat the compressor housing.
- Start the system in the desired operating mode using the control unit button (refer to the system control technical file and the operating instructions in the system control kit).

7 - MAINTENANCE INSTRUCTIONS

IMPORTANT NOTE

- Before doing any work on the installation, make sure it is switched off and all power supplies locked out.
- Also check that the capacitors are discharged.
- Any work must be carried out by personnel qualified and authorised to work on this type of machine.
- Prior to all maintenance and servicing on the refrigerating circuit, one must first shut down the unit then wait a few minutes before installing temperature or pressure sensors. Certain equipment, such as the compressor and piping, may reach temperatures above 100°C and high pressures may lead to serious burns.

7.1 - GENERAL MAINTENANCE

All equipment must be properly maintained in order to provide optimum performance over time. Faulty maintenance can result in the cancellation of the product guaranty. Depending on the products, maintenance operations consist in the cleaning of filters (air, water), internal and external exchangers, casings, and the cleaning and protection of condensate tanks. Treating odours and the disinfection of room surfaces and volumes also contributes to the cleanliness of the air breathed by users.

- Carry out the following operations at least once a year (the frequency depends on the installation and operating conditions):
 - Check for leaks on the refrigerating circuit (according to the order of 7th May 2007).
 - Check for traces of corrosion or oil stains around the refrigerating components.
 - Inspect the composition and the condition of the coolant and check that it does not contain traces of refrigerating fluid.
 - Cleaning the exchangers.
 - Checking the wear parts.
 - Checking the operating instructions and points.
 - Check the safety devices.
 - De-dusting the electrical equipment cabinet.
 - Checking that the electrical connections are secure.
 - Checking the earth connection.
 - Check the hydraulic circuit (clean the filter, water quality, purge, flowrate, pressure, etc.).

7.2 - HEATER SAFETY

- The unit's heater is equipped with an automatic-reset and a manual-reset safety thermostat. These thermostats are located against the heater partition, on the front (see paragraph 2.1).
- These thermostats trip in case of excessive temperature on the heater wall.
- Possible causes:
 - Excessively low or inexistent water flowrate.
 - Improperly purged water system.
- If the manual thermostat trips, correct the fault then reset the thermostat as follows:
 - **Turn off and lock out the unit.**
 - Remove the cover.
 - Press the button in the centre of the manual thermostat.

7.3 - PROTECTION OF HEATER CIRCUITS

- The heater features three heating elements each supplied with 230 V between phases and neutral. Each of these circuits are protected by a modular circuit breaker (**Q1, Q2, Q3**) located inside the electrical box (see paragraph 2.1).

7.4 - CONTROL CIRCUIT PROTECTION

- The control circuit of the heat pump is protected by a modular circuit breaker **Q4** (see paragraph 2.1).
- If tripped:
 - **Turn off and lock out the unit.**
 - Correct the fault.
 - Reset the circuit breaker.

Caution:



The opening of circuit breaker **Q4** disconnects only the control part. In the event of maintenance / servicing, all circuits must be disconnected by opening the main circuit breaker.

7.5 - TROUBLESHOOTING RECOMMENDATIONS

- All maintenance and servicing operations on the refrigerating circuit must be conducted in accordance with standard trade practices and safety rules: recovery of the refrigerant, inert shielded (nitrogen) brazing, etc...
- All brazing operations must be conducted by qualified welders.
- For equipment charged with R 410 A, see specific instructions on page 2.
- This unit is equipped with pressurised equipment, for example piping.
Use only genuine parts listed in the spare parts list for replacing defective refrigeration components.
- Pipes may only be replaced by copper tubing in compliance with standard NF EN 12735-1.
- Leak detection, in the case of pressure testing:
 - Never use oxygen or dry air, as the risk of fire or explosion is present.
 - Use dehydrated nitrogen or a nitrogen and refrigerant mix indicated on the manufacturer's plate.
 - For units equipped with pressure gauges, the test pressure must not exceed the gauges' maximum allowable pressure rating.
- All part replacement with other than genuine parts, all modifications of the refrigerating circuit, all replacement of refrigerant by a fluid other than that indicated on the manufacturer's plate, all use of the unit outside the application limits defined in the documentation, shall result in the cancellation of PED EC marking compliance which shall fall under the liability of the individual who carried out these modifications.
- The technical information, relative to the safety requirements of the various applicable directives, is indicated on the manufacturer's plate of the unit and mentioned on the 1st page of this manual.

8 - ELECTRICAL DIAGRAMS

GB

Symbols of the components

A1	System control board	MOV	Electronic regulator
A2	Control board	MOV1	Electronic regulator
A3	Refrigerating circuit control board	MOV2	Electronic regulator
A4	Power filter board	Q1	R1 circuit breaker
B1	Pressure sensor	Q2	R2 circuit breaker
BD	Diode bridge	Q3	R3 circuit breaker
C1	Capacitor	Q4	Control circuit breaker
C2	Capacitor	RC	Compressor housing heating element
CT	Current transformer	R1	Support heating element
E1	Water pressure switch	R2	Support heating element
F1	Automatic - Heater safety thermostat	R3	Support heating element
F2	Manual - Heater safety thermostat	S1	High battery temperature sensor (C2)
HIC	Hybrid integrated circuit	S2	Low battery temperature sensor (C1)
J1	Water flow switch	S3	Suction temperature sensor (TS)
KA1	Fault relay	S4	Outdoor air temperature sensor (TO)
KA2	Water flow relay	S5	Discharge temperature sensor (TD)
KA3	Power relay	S6	Radiator temperature sensor HIC board
KM1	R1 contactor	S7	Liquid line temperature sensor
KM2	R2 contactor	S8	Water temperature sensor (blue identifying mark)
KM3	R3 contactor	S9	Water temperature sensor (red identifying mark)
KM4	M1 contactor	S11	Water return temperature sensor (System)
L1	Inductance	S12	Water outlet temperature sensor (System)
L2	Inductance	S13	Outdoor air temperature sensor (System)
M1	Circulating pump	XA	Terminal block
M2	Compressor	XB	Terminal block
MF01	Fan motor	XC	Terminal block
MF02	Fan motor	20S	Cycle inversion valve

Colours of the wires

BK	Black	PK	Pink
BN	Brown	RD	Red
BU	Blue	VT	Violet
GN	Green	WH	White
GR	Grey	YE	Yellow
OG	Orange		

GB

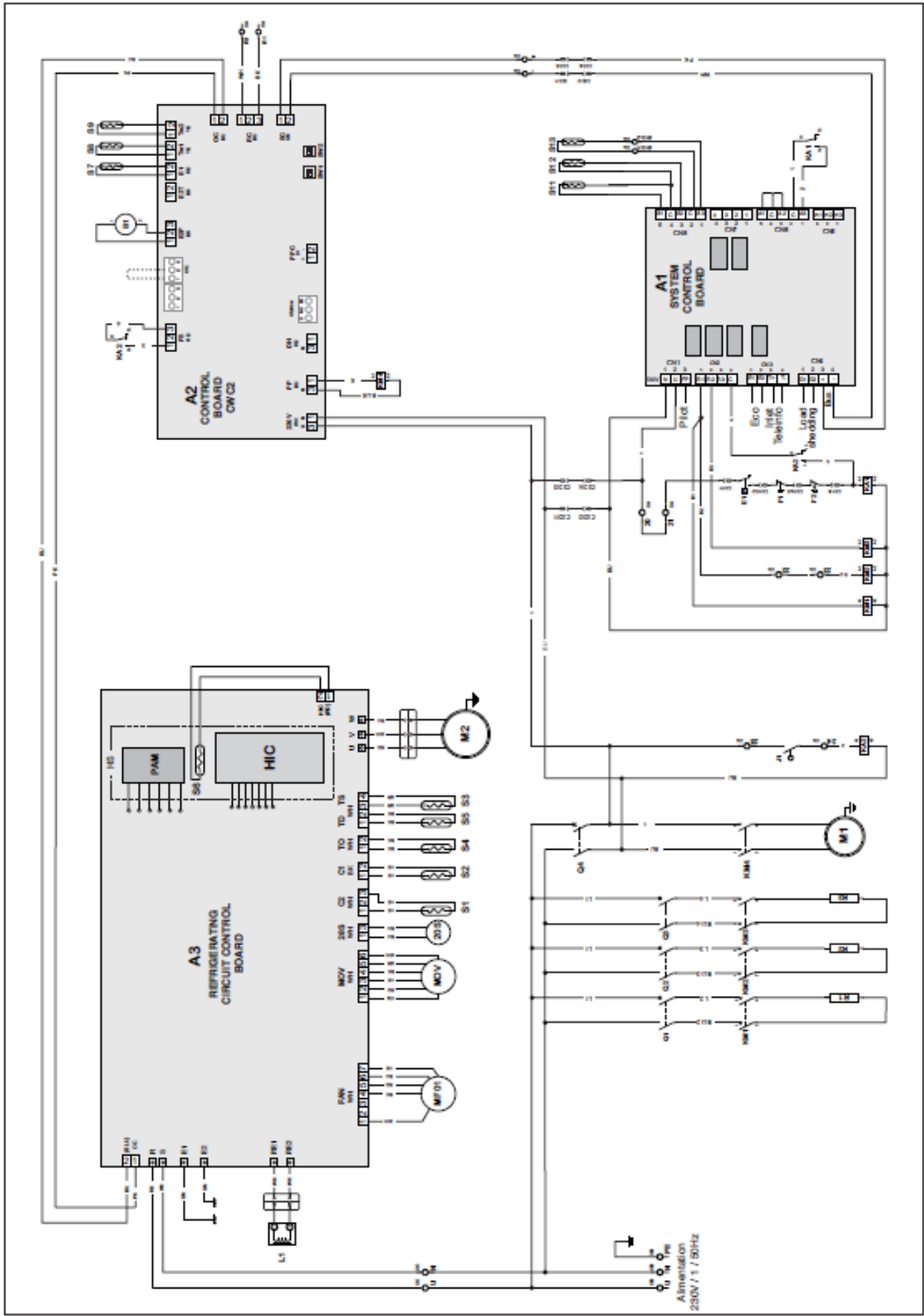

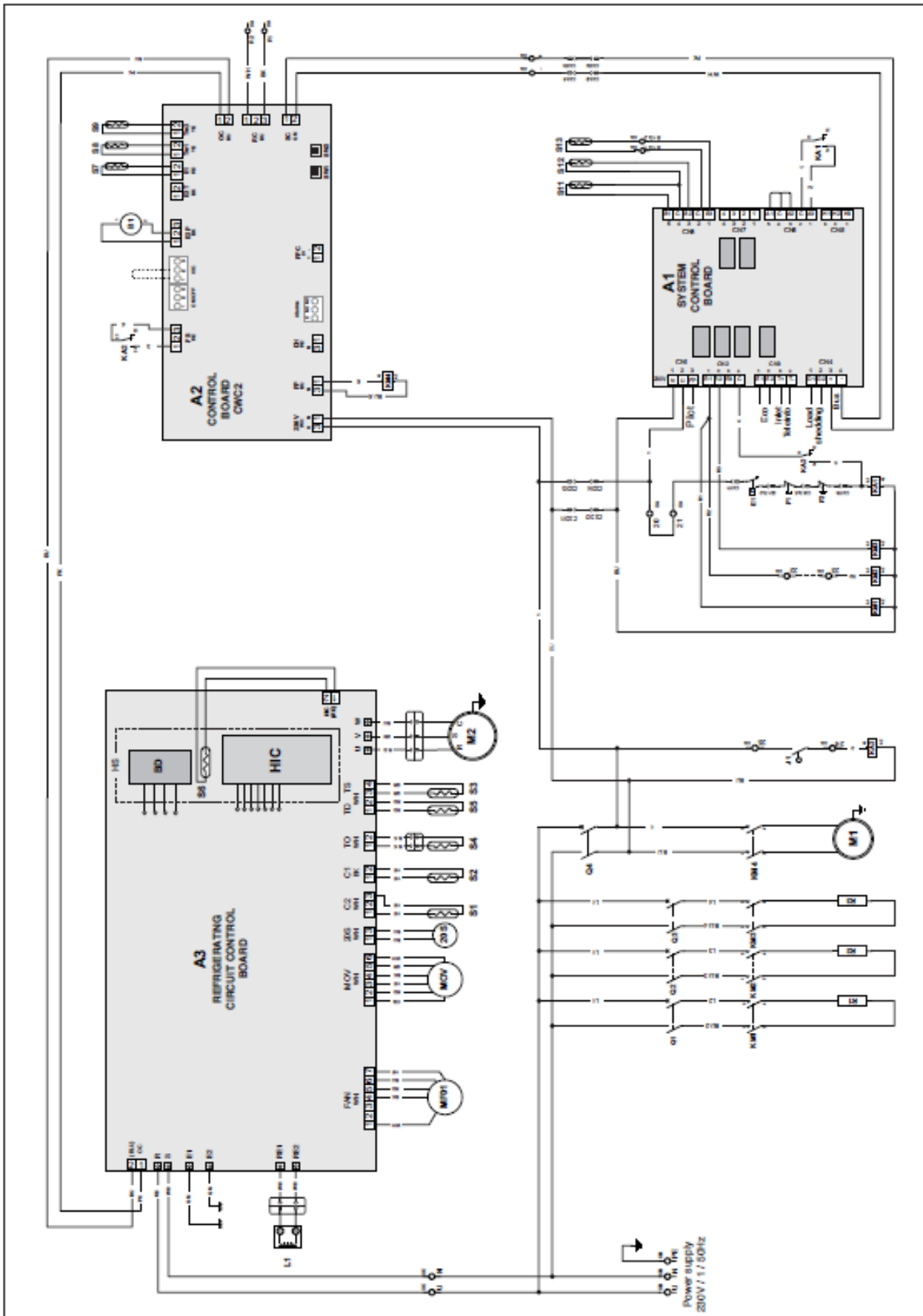

GB

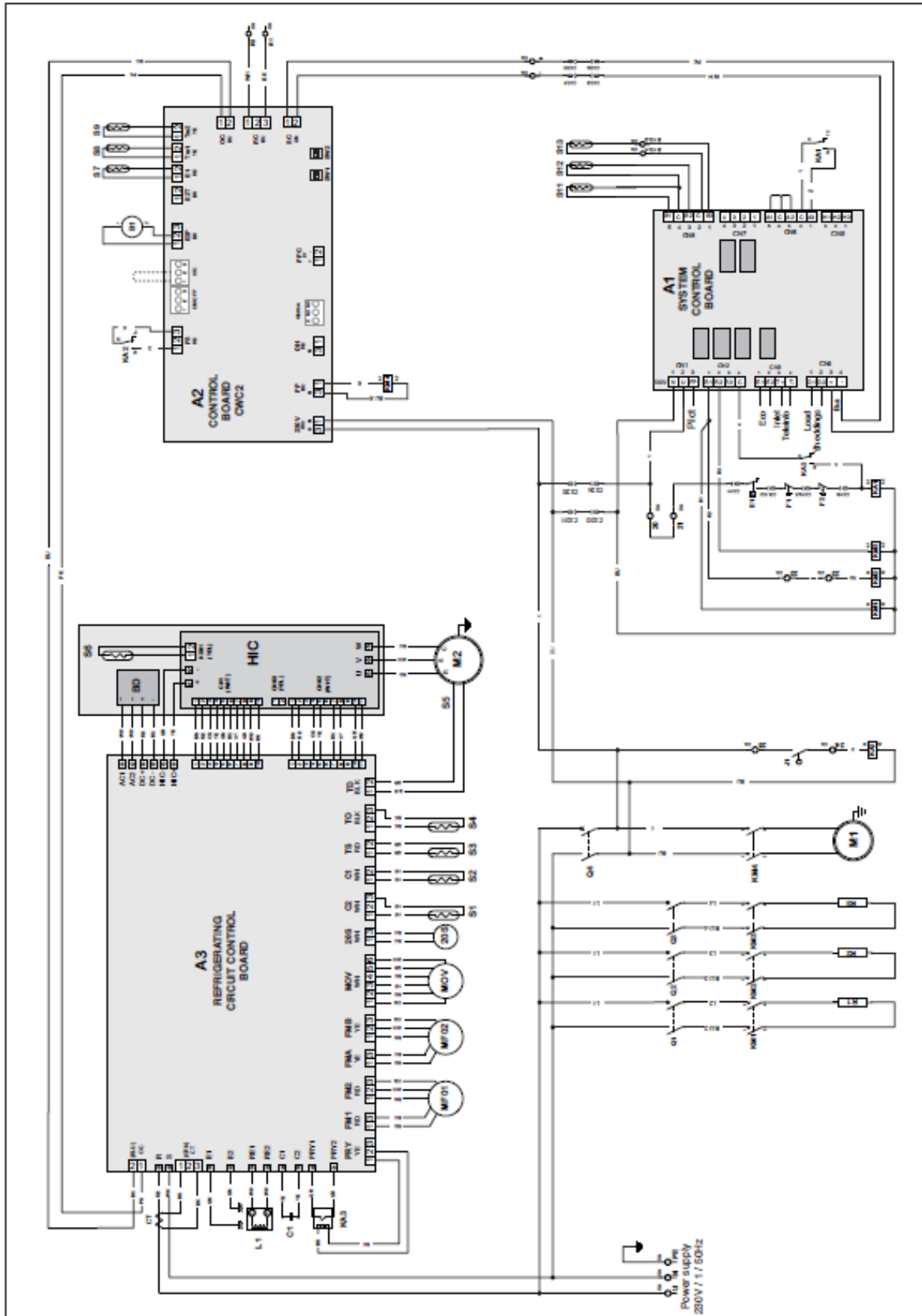

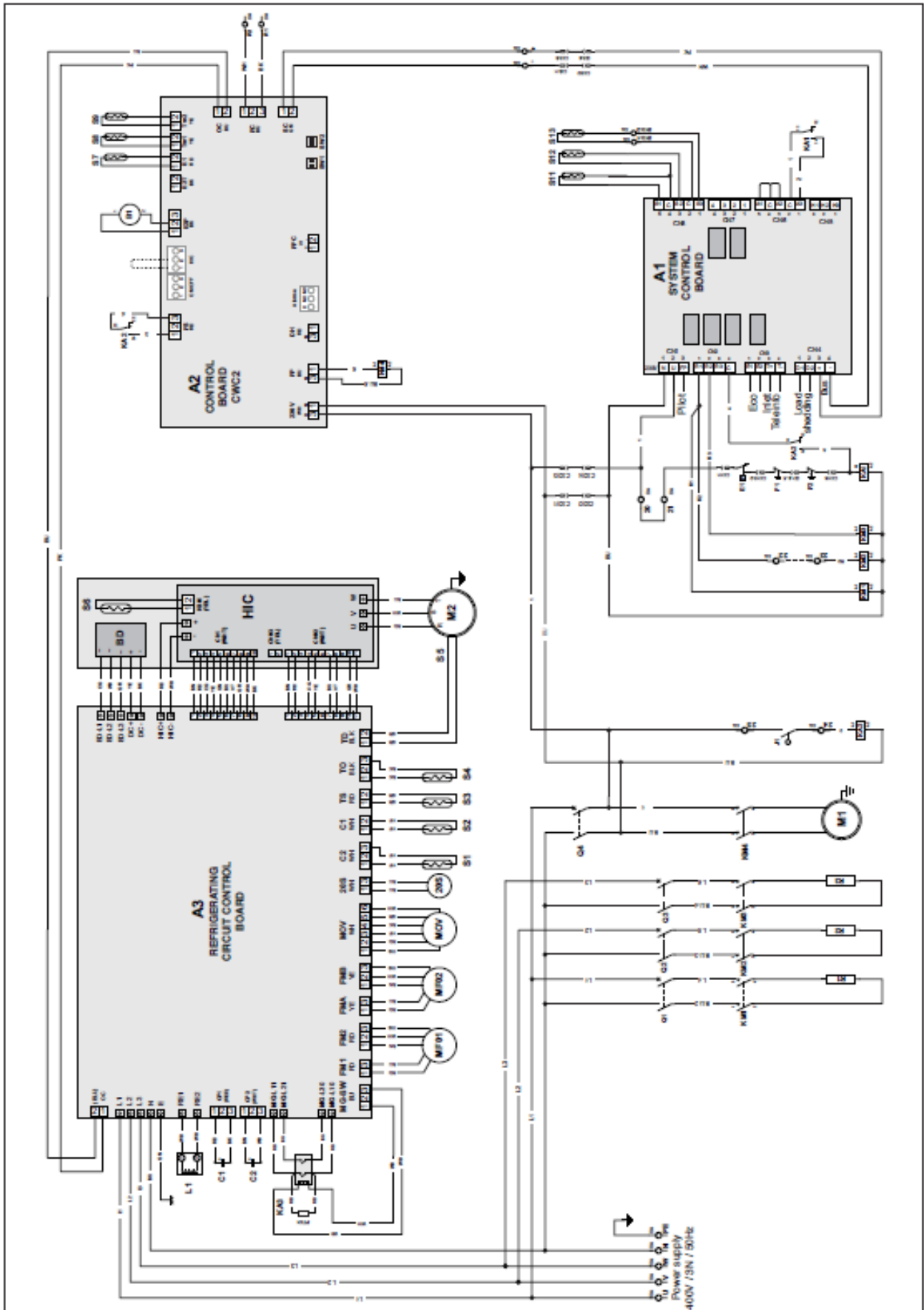

GB

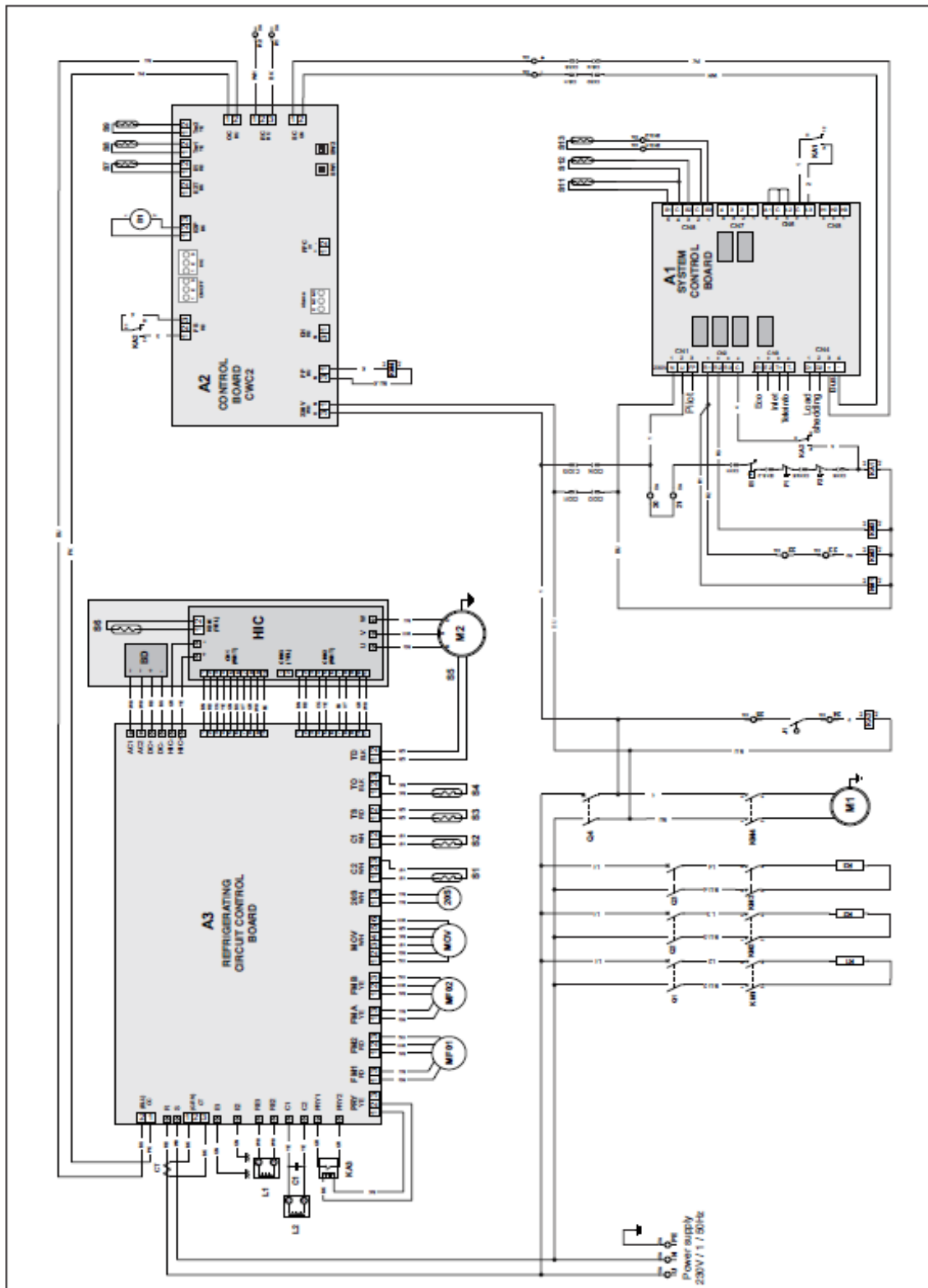

G

